

705G 阀门零件表

■ 705G 阀门零件表 (50mm~300mm)

零件序号	零件名称	数量	备注
1	阀体	1	
2	阀板	1	
3	主阀棒	1	
4	副阀棒	1	2)
6	底盖	1	
10-1	六角螺栓	2	
10-2	弹垫	2	
★ 11	二次密封圈	2	
★ 12	O型圈	1	
★ 14	开口销	1	
★ 30	螺钉	1	
★ 31	填料片	1	
★ 32	阀座	1	
33	底盖密封圈	1	
34	压盖	2	
35	O型圈	1	

■ 705G 阀门零件表 (350mm~600mm)

零件序号	零件名称	数量	备注
1	阀体	1	
2	阀板	1	
3	阀棒	1	
6	底盖	1	
7	压盖	1	
★ 8-1	锥销	2	
★ 8-2	O型圈	4	
★ 9-1	六角螺母	2	
★ 9-2	弹垫	2	
10-1	六角螺栓	2	350mm
		4	400mm~ 600mm
10-2	弹垫	2	350mm
		4	400mm~ 600mm
★ 11	二次密封圈	2	350mm
11	二次密封圈	2	400mm~ 600mm
★ 12	阀座	1	
★ 13	O型圈	1	
★ 14	底盖密封垫	1	
16	钢球	1	400mm~ 600mm
17	空心螺栓	1	400mm~ 600mm
18	自锁螺母	1	400mm~ 600mm
g41	键	1	

705G 驱动部选定表

类型	型号	选定区分	口径 (上段: mm / 下段: inch)													
			50	65	80	100	125	150	200	250	300	350	400	450	500	600
手柄	1T	标准 重负荷	1T-1				1T-2				1T-3					
齿轮箱	2U		2U-0		2U-1		2U-2		2U-3		2U-4		2U-5		2U-6	
行星齿轮箱	2G,2R		2G-1				2G-2		2G-3		2G-4	2R-3			2R-4	
复动式气缸	3E,3A		K30		K70		K170		K370		K700		TGA-125	TGA-140	TGA-180	
单动式气缸	3G,3F 3U,3K		K70S		K170S		K370S		K700S		TG-10S	TG-12S	TG-14S	TG-20S		
单相电动机	4I	ON-OFF	4I-00	4I-0		4I-1	4I-2	4I-2.5		4I-3		4I-4				
三相电动机	4J,4L		SRJ-010				SRJ-020		SRJ-060			LTKD-01 0.2kW /MGH-3	LTKD-01 0.4kW /MGH-3	LTKD-05 0.75kW /MGH-4		

选定区分	标准	
	重负荷	1
		2
		3

700G 压力-温度等级

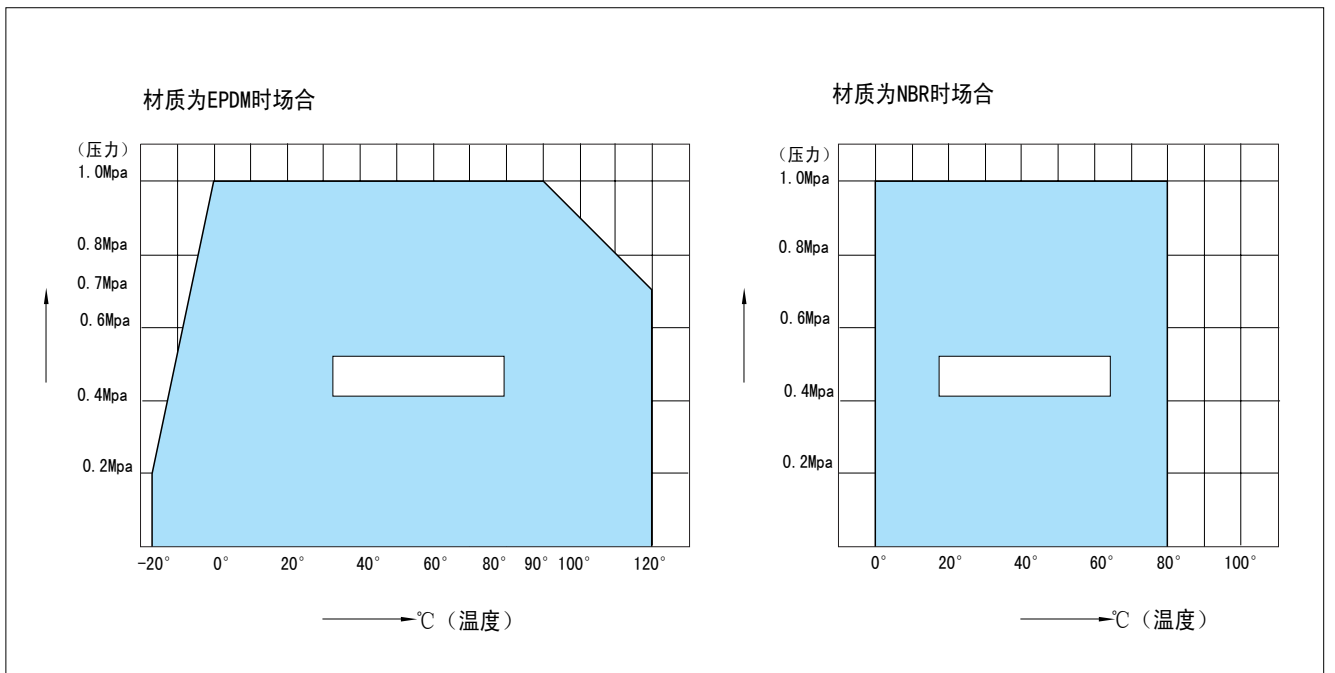

705G

阀棒区分	口径		主要尺寸 (mm)													概算重量 (kg)
	mm	inch	φd	φD	L	H ₁	H ₂	a ₁	a ₂	□S ₁	d ₂	b	t ₂	t	法兰规格	
01	50	2	56	90	43	85	138	21.5	10.5	8	10	-	-	12	F07	2.5
	65	2 1/2	69	115	46	94	151	21.5	10.5	8	10	-	-	12	F07	3.5
	80	3	84	126	46	109	156	22.5	11.5	10	12	-	-	12	F07	4
	100	4	104	146	52	117	167	22.5	11.5	12	14	-	-	12	F07	5
	125	5	130	181	56	143	191	27.5	16.5	14	16	-	-	14	F10	8
	150	6	153.5	211	56	164	202	27.5	16.5	14	18	-	-	14	F10	11
	200	8	199	256	60	186	227	30	20	18	22	-	-	14	F10	15
	250	10	253	322	68	215	280	35	30	24	28	-	-	14	F10	24
	300	12	302	367	78	253	312	35	30	24	32	-	-	16	F12	31
02	350	14	337	410	78	276	348	48	43	-	32	10	3	23	F14	47
	400	16	394	469	102	338	383	54	48	-	40	12	3	23	F14	72
	450	18	441	525	114	368	413	65	59	-	46	14	3.5	23	F14	96
	500	20	492	580	127	403	453	79	73	-	50	14	3.3	28	F14	127
	600	24	584	682	154	458	528	79	73	-	55	16	4	28	F16	191

法兰尺寸表

法兰规格	□S	φC ₁	N	B.H.
F07	70	70	4	9
F10	102	102	4	11
F12	125	125	4	13
F14	140	140	4	19
F16	165	165	4	23

阀棒区分
01: 角
02: 圆 (键连接)

705G 50mm~300mm

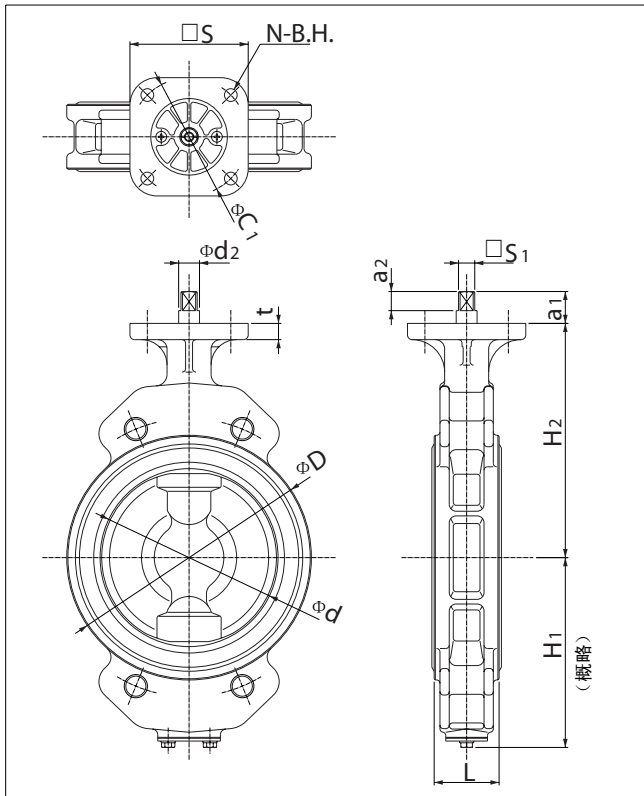

705G 350mm~600mm

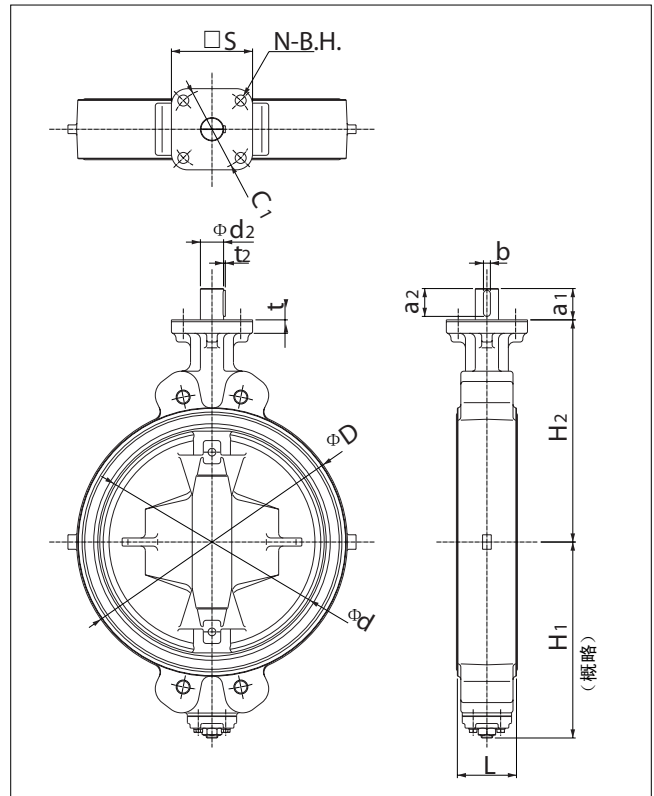

705G

手柄式 705G-1T (50mm~200mm)

口径		主要尺寸 (mm)							手柄型号	概算重量 (kg)
mm	inch	ϕd	ϕD	L	H ₁	H ₂	H ₃	W		
50	2	56	90	43	85	138	66	200	1T-1	3.1
65	2 1/2	69	115	46	94	151	66	200	1T-1	4.1
80	3	84	126	46	109	156	66	200	1T-1	4.6
100	4	104	146	52	117	167	66	200	1T-1	5.6
125	5	130	181	56	143	191	92	300	1T-2	9.3
150	6	153.5	211	56	164	202	92	300	1T-2	12.3
200	8	199	256	60	186	227	97	350	1T-3	16.7

705G-1T

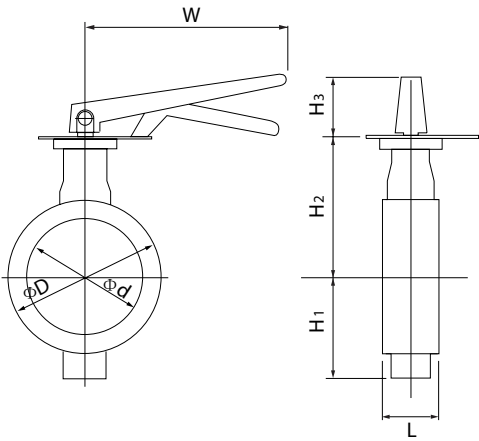

手柄 (1T) 选择方向

1TLS (标准)	1TLR	1TRS	1TRR
1TXS	1TXR	1TVS	1TVR

齿轮箱式 705G-2U (50mm~600mm)

口 径		主 要 尺 寸 (mm)										齿轮箱型号	概算重量 (kg)
mm	inch	ϕd	ϕD	L	H ₁	H ₂	H ₃	E	K	F	W		
50	2	56	90	43	85	138	29.5	36	46	160	100	2U-0	4.8
65	2 1/2	69	115	46	94	151	29.5	36	46	160	100	2U-0	5.8
80	3	84	126	46	109	156	29.5	36	46	160	100	2U-1	6.3
100	4	104	146	52	117	167	29.5	36	46	160	100	2U-1	7.3
125	5	130	181	56	143	191	34.5	44	53	173.5	160	2U-2	12.2
150	6	153.5	211	56	164	202	34.5	44	53	173.5	160	2U-2	16
200	8	199	256	60	186	227	41.5	67	75	198	200	2U-3	23
250	10	253	322	68	215	280	41.5	67	75	198	200	2U-3	32
300	12	302	367	78	253	312	48	87.5	90	222.5	200	2U-4	45
350	14	337	410	78	276	348	48	87.5	90	222.5	280	2U-4	63
400	16	394	469	102	338	383	50	90	105	266	280	2U-5	88
450	18	441	525	114	368	413	50	90	105	266	280	2U-5	112
500	20	492	580	127	403	453	50	90	105	266	280	2U-5	143
600	24	584	682	154	458	528	61	113	140	352	400	2U-6	222

■ 705G-2U

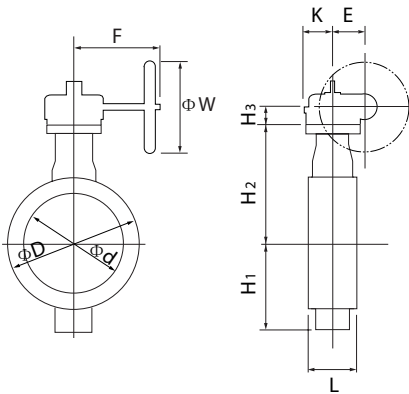

■ 齿轮箱 (2U) 选择方向

2UA (标准)	2UAR	2UB	2UBR

705G

齿轮箱式 705G-2U (50mm~600mm)

口 径		主 要 尺 寸 (mm)							行星齿轮箱型号	概算重量 (kg)
mm	inch	ϕd	ϕD	L	H ₁	H ₂	H ₃	W		
50	2	56	90	43	85	138	136	100	2G-1	5.4
65	2 1/2	69	115	46	94	151	136	100	2G-1	6.4
80	3	84	126	46	109	156	136	100	2G-1	6.9
100	4	104	146	52	117	167	136	100	2G-1	7.9
125	5	130	181	56	143	191	133	100	2G-2	11.8
150	6	153.5	211	56	164	202	133	100	2G-2	14.8
200	8	199	256	60	186	227	151	200	2G-3	22.1
250	10	253	322	68	215	280	151	200	2G-3	32
300	12	302	367	78	253	312	161	200	2G-4	39
350	14	337	410	78	276	348	409	355	2R-3	80
400	16	394	469	102	338	383	409	355	2R-3	105
450	18	441	525	114	368	413	409	355	2R-3	130
500	20	492	580	127	403	453	409	355	2R-3	161
600	24	584	682	154	458	528	498	450	2R-4	244

705G-2G/2R

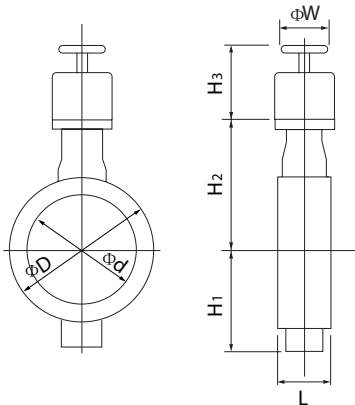

■ 标准选定

口 径		主 要 尺 寸 (mm)										气缸型号	概算重量 (kg)
mm	inch	ϕd	ϕD	L	H ₁	H ₂	H ₃	A	P	f ₁	f ₂		
50	2	56	90	43	85	138	113	218.5	113.5	35	50	K30	3.7
65	2 1/2	69	115	46	94	151	113	218.5	113.5	35	50	K30	4.4
80	3	84	126	46	109	156	133	268	138	53	51	K70	6.5
100	4	104	146	52	117	167	133	268	138	53	51	K70	7.3
125	5	130	181	56	143	191	133	268	138	53	51	K70	9.3
150	6	153	211	56	164	202	157	332	171	65	58	K170	13.6
200	8	199	256	60	186	227	184	411	209	83	69	K370	22
250	10	253	322	68	215	280	184	411	209	83	69	K370	29.6
300	12	302	367	78	253	312	224	520	262	101	85	K700	46.5
350	14	337	410	78	276	348	224	520	262	101	85	K700	71.5

■ 重负荷选定

口 径		主 要 尺 寸 (mm)										气缸型号	概算重量 (kg)
mm	inch	ϕd	ϕD	L	H ₁	H ₂	H ₃	A	P	f ₁	f ₂		
50	2	56	90	43	85	138	113	218.5	113.5	35	50	K30	3.7
65	2 1/2	69	115	46	94	151	113	218.5	113.5	35	50	K30	4.4
80	3	84	126	46	109	156	133	268	138	53	51	K70	6.5
100	4	104	146	52	117	167	157	332	171	65	58	K170	10
125	5	130	181	56	143	191	157	332	171	65	58	K170	12
150	6	153.5	211	56	164	202	157	332	171	65	58	K170	13.6
200	8	199	256	60	186	227	184	411	209	83	69	K370	22
250	10	253	322	68	215	280	184	411	209	83	69	K370	29.6
300	12	302	367	78	253	312	224	520	262	101	85	K700	46.5

选 定 分 区	标准	
	重 负 荷	1
		2
		3
4		

■ 705G-3E

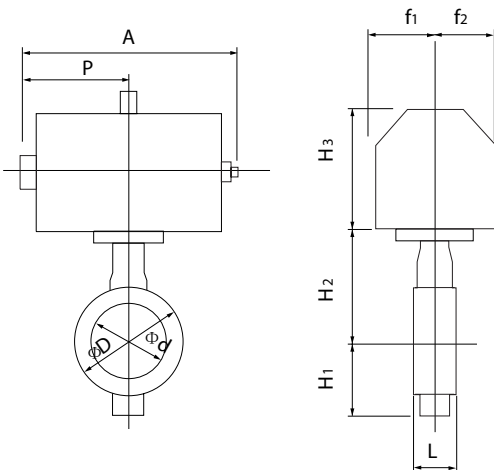

■ 气缸 (3E) 选择方向

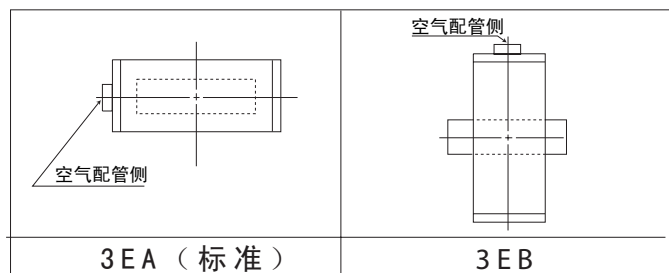

705G

复动气缸式 705G-3A (400mm~600mm)

■ 标准选定

口 径		主 要 尺 寸 (mm)										气缸型号	概算重量 (kg)
mm	inch	ϕd	ϕD	L	H ₁	H ₂	H ₃	A	P	f ₁	f ₂		
400	16	394	469	102	338	383	364	743	381	100	164	TGA-125	110
450	18	441	525	114	368	413	412	810	417	100	180	TGA-140	150
500	20	492	580	127	403	453	465	939	483	130	202	TGA-160	217
600	24	584	682	154	458	528	478	1053	543	130	218	TGA-180	330

■ 重负荷选定

口 径		主 要 尺 寸 (mm)										气缸型号	概算重量 (kg)
mm	inch	ϕd	ϕD	L	H ₁	H ₂	H ₃	A	P	f ₁	f ₂		
350	14	337	410	78	276	348	364	743	381	100	164	TGA-125	85
400	16	394	469	102	338	383	412	810	417	100	180	TGA-140	124
450	18	441	525	114	368	413	465	939	483	130	202	TGA-160	197
500	20	492	580	127	403	453	465	939	483	130	202	TGA-160	217
600	24	584	682	154	458	528	525	1163	599	160	253	TGA-200	390

■ 705G-3A

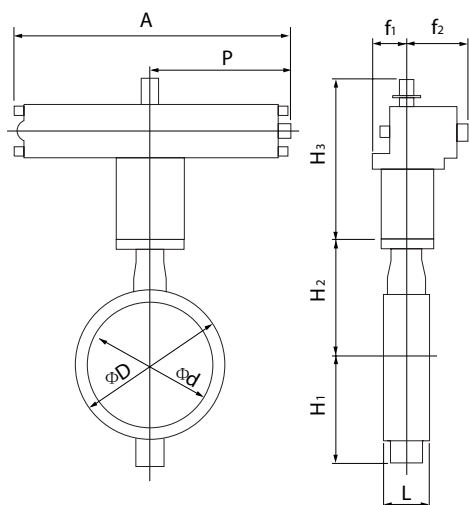

选定区分	标准	
	重负荷	1 2 3 4

■ 气缸 (3A) 选择方向

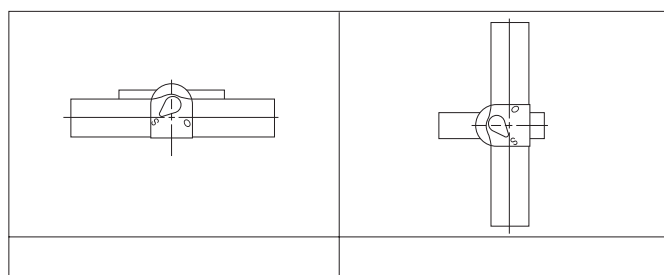

3AA (标准)

3AB

■ 标准选定

口径		主要尺寸 (mm)										气缸型号	概算重量 (kg)
mm	inch	ϕd	ϕD	L	H ₁	H ₂	H ₃	A	P	f ₁	f ₂		
50	2	56	90	43	85	138	133	362	178.5	53	51	K70S	6.9
65	2 1/2	69	115	46	94	151	157	446	220.5	65	58	K170S	11.4
80	3	84	126	46	109	156	157	446	220.5	65	58	K170S	11.5
100	4	104	146	52	117	167	157	446	220.5	65	58	K170S	12.3
125	5	130	181	56	143	191	184	547	271	83	69	K370S	21.2
150	6	153.5	211	56	164	202	184	547	271	83	69	K370S	22.8
200	8	199	256	60	186	227	224	709	352	101	85	K700S	40.3
250	10	253	322	68	215	280	224	709	352	101	85	K700S	47.9

■ 重负荷选定

口径		主要尺寸 (mm)										气缸型号	概算重量 (kg)
mm	inch	ϕd	ϕD	L	H ₁	H ₂	H ₃	A	P	f ₁	f ₂		
50	2	56	90	43	85	138	133	362	178.5	53	51	K70S	6.9
65	2 1/2	69	115	46	94	151	157	446	220.5	65	58	K170S	11.4
80	3	84	126	46	109	156	157	446	220.5	65	58	K170S	11.5
100	4	104	146	52	117	167	184	547	271	83	69	K370S	19.2
125	5	130	181	56	143	191	184	547	271	83	69	K370S	21.2
150	6	153.5	211	56	164	202	224	709	352	101	85	K700S	36.9

选定分区	标准	
	重负荷	1
		2
		3
4		

■ 705G-3F

■ 705G-3G

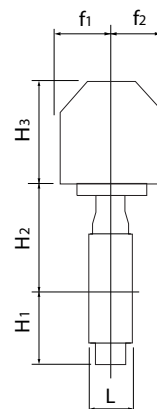
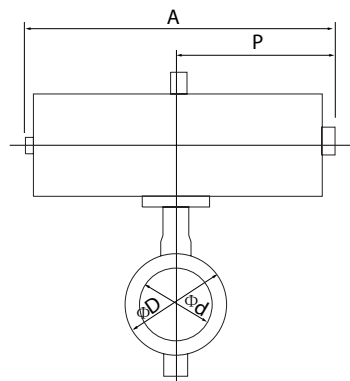
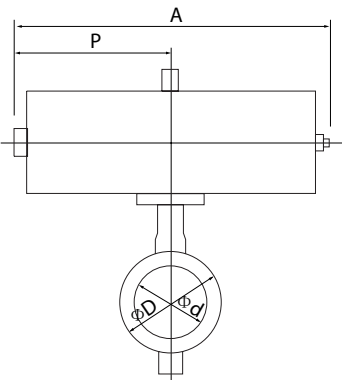

■ 气缸 (3F) 选择方向

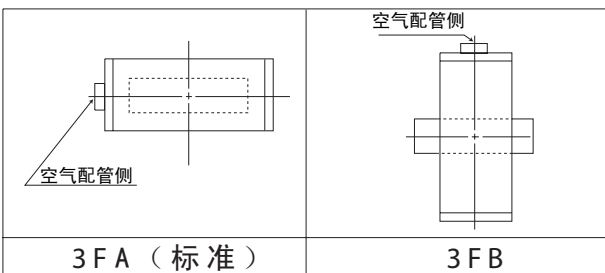

■ 气缸 (3G) 选择方向

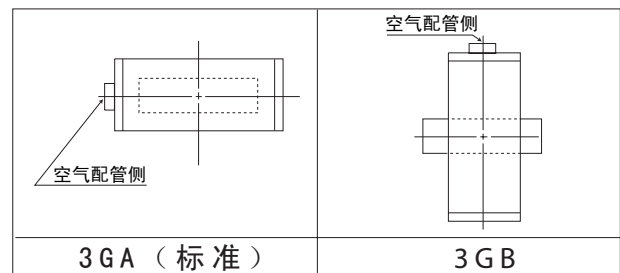

705G

单动气缸式 705G-3U (加压开: 200mm~600mm)/705G-3K (加压闭: 200mm~600mm)

标准选定

口径		主要尺寸 (mm)										气缸型号	概算重量 (kg)
mm	inch	Φd	D	L	H ₁	H ₂	H ₃	A	P	f ₁	f ₂		
250	10	253	322	68	215	280	307	945	585	70	165	TG-10S	80
300	12	302	367	78	253	312	307	1080	720	94	206	TG-12S	132
350	14	337	410	78	276	348	307	1080	720	94	206	TG-12S	148
400	16	394	469	102	338	383	340	1255	865	131	257	TG-14S	270
450	18	441	525	114	368	413	340	1255	865	131	257	TG-14S	294
500	20	492	580	127	403	453	474	1655	1095	164	348	TG-20S	538
600	24	584	682	154	458	528	474	1655	1095	164	348	TG-20S	602

mm	inch	d	D	L	H ₁	H ₂	H ₃	A	P	f ₁	f ₂		
200	8	199	256	60	186	227	307	945	585	70	165	TG-10S	71
250	10	253	322	68	215	280	307	1080	720	94	206	TG-12S	125
300	12	302	367	78	253	312	307	1080	720	94	206	TG-12S	132
350	14	337	410	78	276	348	340	1255	865	131	257	TG-14S	244
400	16	394	469	102	338	383	340	1255	865	131	257	TG-14S	270
450	18	441	525	114	368	413	474	1655	1095	164	348	TG-20S	507
500	20	492	580	127	403	453	474	1655	1095	164	348	TG-20S	538
600	24	584	682	154	458	528	474	1655	1095	164	348	TG-20S	602

1	
2	
3	
4	

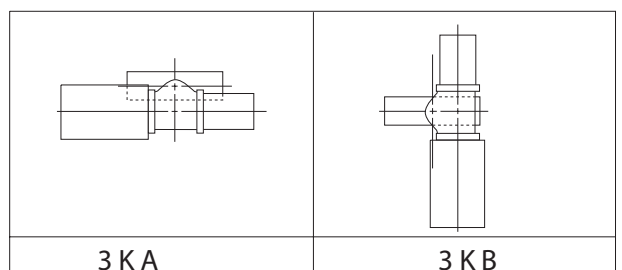
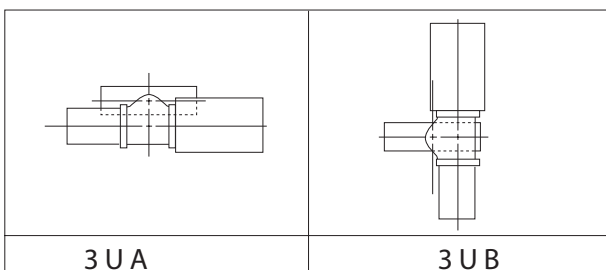
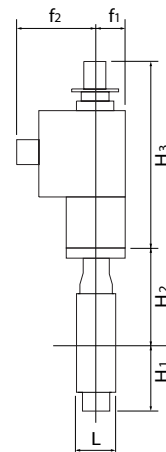
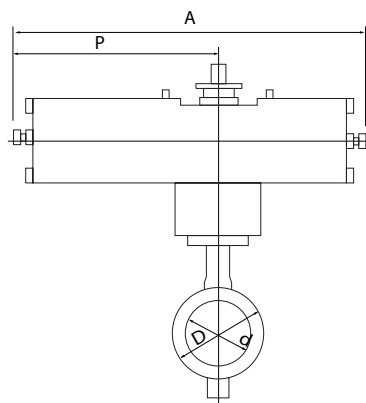
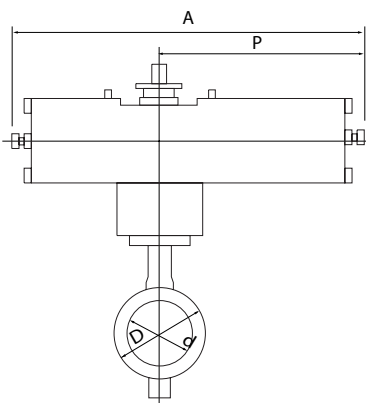

单相电动机 705G-4I (50mm~500mm)

口径		主要尺寸 (mm)										电动机型号	概算重量 (kg)
mm	inch	d	D	L	H ₁	H ₂	H ₃	A	P	F	K		
50	2	56	90	43	85	138	120	161	84	58	45	4I-00	5.3
							150	202	100	85	54	4I-0	6.7
65	2 1/2	69	115	46	94	151	150	202	100	85	54	4I-0	7.7
80	3	84	126	46	109	156	150	202	100	85	54	4I-0	8.2
100	4	104	146	52	117	167	165	252	138	126	65	4I-1	11.4
125	5	130	181	56	143	191	198	310	167	154	85	4I-2	19.2
150	6	153.5	211	56	164	202	198	310	167	154	85	4I-2	22.2
200	8	199	256	60	186	227	198	310	167	154	85	4I-2.5	26.2
250	10	253	322	68	215	280	198	310	167	154	85	4I-2.5	37
300	12	302	367	78	253	312	230	388	223	246	136	4I-3	55
350	14	337	410	78	276	348	230	388	223	246	136	4I-3	70
400	16	394	469	102	338	383	230	388	223	246	136	4I-3	95
							255	388	223	246	136	4I-4	101
450	18	441	525	114	368	413	230	388	223	246	136	4I-4	125
500	20	492	580	127	403	453	230	388	223	246	136	4I-4	156

705G-4I

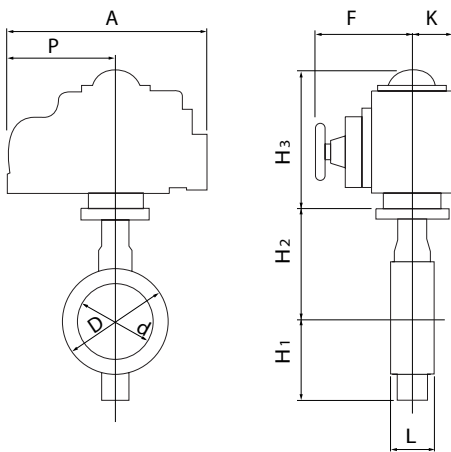

单相电动机 (4I) 选择方向

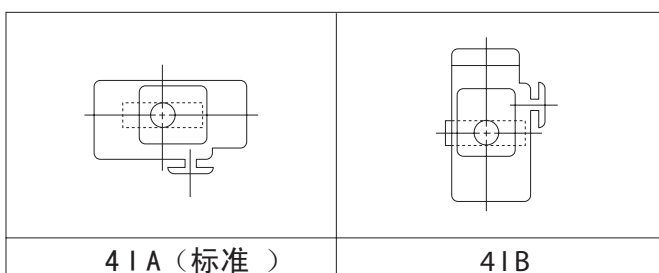

705G

三相电动机 705G-4J (50mm~300mm)

口径		主要尺寸 (mm)											电动机型号	概算重量 (kg)
mm	inch	d	D	L	H ₁	H ₂	H ₃	H ₄	A	P	F	K		
50	2	56	90	43	85	138	218	3.2	353	167	286	104	SRJ-010	16.2
65	2 1/2	69	115	46	94	151	218	3.2	353	167	286	104	SRJ-010	17.2
80	3	84	126	46	109	156	218	3.2	353	167	286	104	SRJ-010	17.7
100	4	104	146	52	117	167	218	3.2	353	167	286	104	SRJ-010	18.5
125	5	130	181	56	143	191	218	15	353	167	286	104	SRJ-020	22.2
150	6	153.5	211	56	164	202	218	15	353	167	286	104	SRJ-020	25
200	8	199	256	60	186	227	235	3.2	393	191	330	130	SRJ-060	43
250	10	253	322	68	215	280	235	3.2	393	191	330	130	SRJ-060	56
300	12	302	367	78	253	312	235	20	393	191	330	130	SRJ-060	67

705G-4J

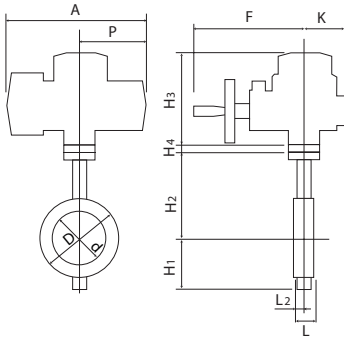

三相电动机 (4J) 选择方向

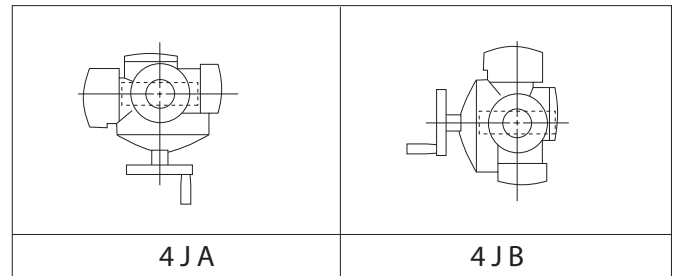

三相电动机 705G-4L (350mm~600mm)

口径		主要尺寸 (mm)											电动机型号	概算重量 (kg)
mm	inch	d	D	L	H ₁	H ₂	H ₃	E	K	F	M	P		
350	14	337	410	78	276	348	487	117	164	533	357	230	LTKD-01 0.2kW /MGH-3	148
400	16	394	469	102	338	383	487	117	164	533	357	230	LTKD-01 0.2kW /MGH-3	173
450	18	441	525	114	368	413	487	117	164	533	370	230	LTKD-01 0.4kW /MGH-3	201
500	20	492	580	127	403	453	487	117	164	533	370	230	LTKD-01 0.4kW /MGH-3	232
600	24	584	682	154	458	528	590	140	198	637	440	375	LTKD-05 0.75kW /MGH-4	398

705G-4L

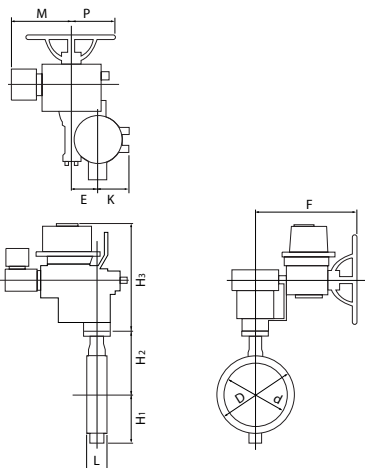

单相电动机 (4L) 选择方向

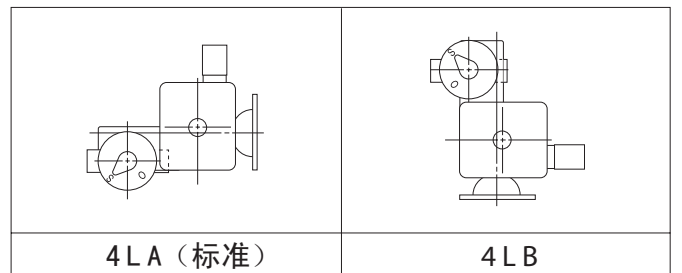

705G Cv值/压力损失系数

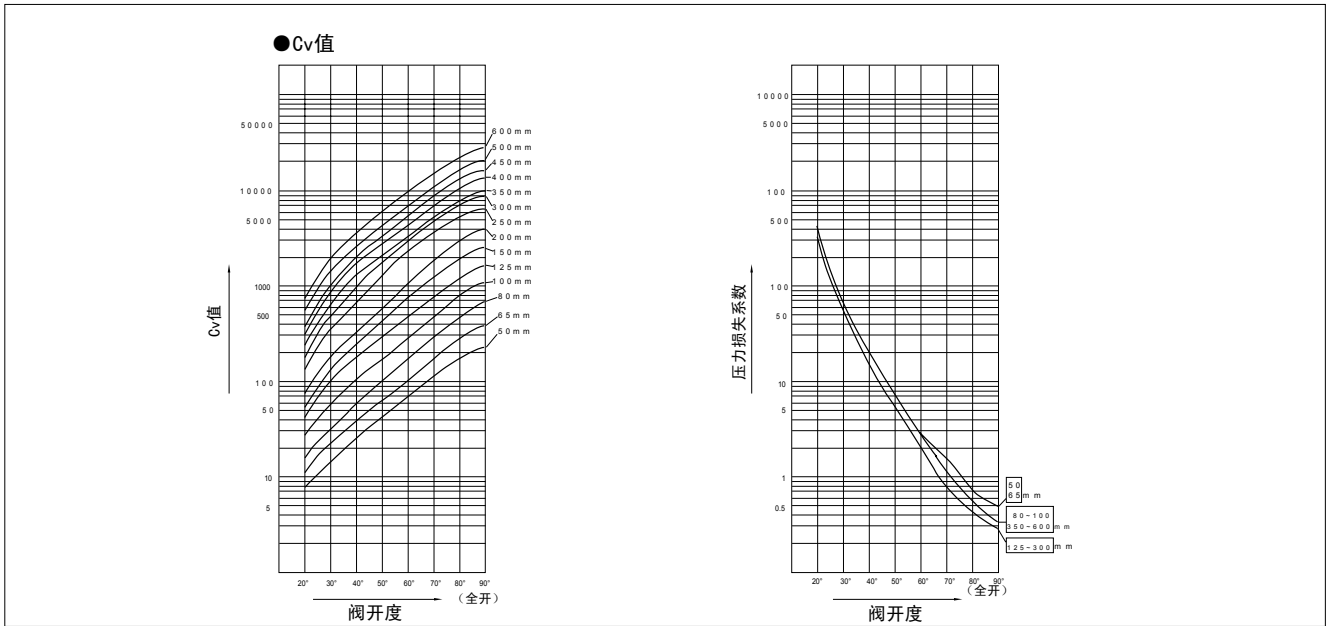

705G Cv值

口径		阀开度							
mm	inch	20°	30°	40°	50°	60°	70°	80°	90°
50	2	8	15	25	40	64	103	160	200
65	2 1/2	12	25	41	64	102	162	260	320
80	3	15	33	57	95	163	271	450	580
100	4	27	58	100	162	269	444	749	880
125	5	45	109	189	295	453	719	1144	1590
150	6	60	148	262	423	685	1147	1897	2800
200	8	67	188	347	576	969	1698	2902	4300
250	10	130	351	675	1225	2125	3375	5091	6200
300	12	194	487	972	1764	3011	4966	7412	8900
350	14	232	662	1350	2030	3294	5167	7832	9620
400	16	468	964	1648	2724	4529	6815	10553	12700
450	18	583	1202	2068	3448	5692	8384	13116	15500
500	20	758	1555	2656	4379	7214	10845	17100	19800
600	24	1037	2141	3681	6129	10106	14911	22827	27300

705G 压力损失系数

口径		阀开度							
mm	inch	20°	30°	40°	50°	60°	70°	80°	90°
50	2	257	68	25	10	4	2	1	0.4
65	2 1/2	310	75	28	11	4	2	1	0.4
80	3	394	83	27	10	3	1	0.4	0.2
100	4	350	78	26	10	4	1	0.4	0.3
125	5	316	53	18	7	3	1	0.4	0.2
150	6	348	57	18	7	3	1	0.3	0.1
200	8	849	106	31	11	4	1	0.4	0.2
250	10	528	72	20	6	2	1	0.3	0.2
300	12	488	78	20	6	2	1	0.3	0.2
350	14	531	65	16	7	3	1	0.4	0.3
400	16	227	54	18	7	2	1	0.4	0.3
450	18	239	56	19	7	3	1	0.4	0.3
500	20	218	52	18	7	2	1	0.4	0.3
600	24	247	58	20	7	3	1	1	0.3

705G

705G (FCD450本体/FC250本体) 法兰规格表

口 径		JIS		ANSI		BS4504		DIN		BS10 Table E
mm	inch	5K	10K	125Lb	150Lb	PN10	PN16	NP10	NP16	
50	2	D/T	D/T	D/T	D/T	D/T	D/T	D/T	D/T	D/T
65	2 1/2	D/T	D/T	D/T	D/T	D/T	D/T	D/T	D/T	D/T
80	3	D/T	D/T	D/T	D/T	D/T	D/T	D/T	D/T	D/T
100	4	D/T	D/T	D/T	D/T	D/T	D/T	D/T	D/T	D/T
125	5	D/T	D/T	D/T	D/T	D/T	D/T	D/T	D/T	D/T
150	6	D/T	D/T	D/T	D/T	D/T	D/T	D/T	D/T	D/T
200	8	D/T	D/T	D/T	D/T	D/T	D/T	D/T	D/T	D/T
250	10	D/T	D/T	D/T	D/T	D/T	D/T	D/T	D/T	D/T
300	12	D/T	D/T	D/T	D/T	D/T	D/T	D/T	D/T	D/T
350	14	D/T	D/T	D/T	D/T	D/T	D/T	D/T	D/T	D/T
400	16	D/T	D/T	D/T	D/T	D/T	D/T	D/T	D/T	D/T
450	18	D/T	D/T	D/T	D/T	D/T	D/T	D/T	D/T	D/T
500	20	D/T	D/T	D/T	D/T	D/T	D/T	D/T	D/T	D/T
600	24	T	T	T	T	T	T	T	T	T

705G A图连接方法及VP管使用情况表

口径		SGP管	STPY管	Sch20	Sch40	VP管 (TSフランジ)	Sch10S	Sch20S	最小配管内径 (mm)
mm	inch								
50	2	○	-	○	○	○	○	○	34
65	2 1/2	○	-	○	○	○	○	○	51
80	3	○	-	○	○	○	○	○	70
100	4	○	-	○	○	○	○	○	91
125	5	○	-	○	○	○	○	○	118
150	6	○	-	○	○	○	○	○	144
200	8	○	-	○	○	○	○	○	194
250	10	○	-	○	○	○	○	○	246
300	12	○	-	○	○	○	○	○	294
350	14	○	○	○	○	○	-	-	330
400	16	○	○	○	○	-	-	-	381
450	18	○	○	○	○	-	-	-	427
500	20	○	○	○	○	-	-	-	477
600	24	-	○	○	○	-	-	-	567

705G B图连接方法及VP管使用情况表

口径		SGP管	STPY管	Sch20	Sch40	Sch10S	Sch20S
mm	inch						
50	2	○	-	○	○	○	○
65	2 1/2	○	-	○	○	○	○
80	3	○	-	○	○	○	○
100	4	○	-	○	○	○	○
125	5	○	-	○	○	○	○
150	6	○	-	○	○	○	○
200	8	○	-	○	○	○	○
250	10	○	-	○	○	○	○
300	12	○	-	○	○	○	○
350	14	○	○	○	○	-	-
400	16	○	○	○	○	-	-
450	18	○	○	○	○	-	-
500	20	○	○	○	○	-	-
600	24	-	○	○	○	-	-

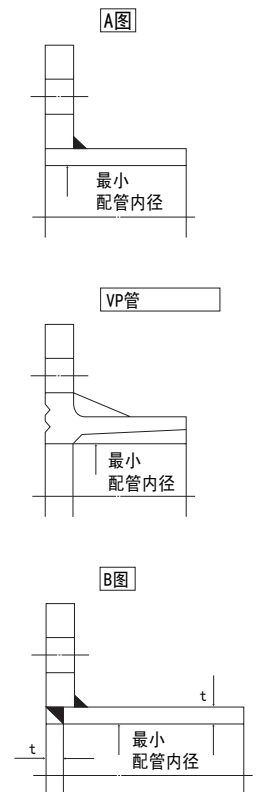

■六角螺栓

-口径		JIS 5K	JIS 10K
mm	inch	六角螺栓	六角螺栓
50	2	4-M12×90× 30	4-M16× 105× 40
65	2 1/2	4-M12× 90× 30	4-M16× 105× 40
80	3	4-M16× 105× 40	8-M16× 110× 40
100	4	8-M16× 110× 40	8-M16× 110× 40
125	5	8-M16× 110× 40	8-M20× 120× 50
150	6	8-M16× 120× 40	8-M20× 130× 50
200	8	8-M20× 130× 50	12-M20× 135× 50
250	10	12-M20× 135× 50	12-M22× 150× 60
300	12	12-M20× 150× 50	16-M22× 160× 60
350	14	12-M22× 160× 60	16-M22× 160× 60
400	16	16-M22× 175× 45	16-M24× 190× 45
450	18	16-M22× 185× 45	20-M24× 205× 45
500	20	20-M22× 205× 45	20-M24× 215× 45

■自锁螺栓

口径		JIS5K	JIS10K	ANSI125Lb/150Lb
mm	inch	自锁螺栓	自锁螺栓	自锁螺栓
50	2	4-M12× 105× 25	4-M16× 120× 30	4-U5/8-11UNC × 145× 45
65	2 1/2	4-M12× 110× 25	4-M16× 125× 30	4-U5/8-11UNC × 155× 50
80	3	4-M16× 120× 30	8-M16× 125× 30	4-U5/8-11UNC × 155× 50
100	4	8-M16× 130× 30	8-M16× 130× 30	8-U5/8-11UNC × 165× 50
125	5	8-M16× 130× 30	8-M20× 150× 40	8-U3/4-10UNC × 175× 55
150	6	8-M16× 140× 35	8-M20× 155× 40	8-U3/4-10UNC × 175× 55
200	8	8-M20× 155× 40	12-M20× 155× 40	8-U3/4-10UNC × 175× 55
250	10	12-M20× 165× 40	12-M22× 175× 45	12-U7/8- 9UNC × 215× 55
300	12	12-M20× 175× 40	16-M22× 185× 45	12-U7/8- 9UNC × 215× 55
350	14	12-M22× 185× 45	16-M22× 185× 45	12-U1 - 8UNC × 225
400	16	16-M22× 205× 45	16-M24× 220× 50	16-U1 - 8UNC × 255
450	18	16-M22× 225× 45	20-M24× 230× 50	16-U1 1/8- 8UN × 280
500	20	20-M22× 230× 45	20-M24× 245× 50	20-U1 1/8- 8UN × 295

■ 六角螺栓

口径		JIS 5K		JIS 10K	
mm	inch	六角螺栓	长螺栓	六角螺栓	长螺栓
50	2		8-M12× 30× 28		8-M16× 35× 32
65	2 1/2		8-M12× 35× 33		8-M16× 35× 32
80	3		8-M16× 35× 33	4-M16× 110× 40	8-M16× 35× 32
100	4	4-M16× 110× 40	8-M16× 40× 38	4-M16× 110× 40	8-M16× 40× 38
125	5	4-M16× 110× 40	8-M16× 40× 38	4-M20× 120× 50	8-M20× 45× 41
150	6	4-M16× 120× 40	8-M16× 40× 38	4-M20× 130× 50	8-M20× 45× 41
200	8	4-M20× 130× 50	8-M20× 45× 41	8-M20× 135× 50	8-M20× 50× 46
250	10	8-M20× 135× 50	8-M20× 50× 46	8-M22× 150× 60	8-M22× 55× 50
300	12	8-M20× 150× 50	8-M20× 55× 51	12-M22× 160× 60	8-M22× 60× 55
350	14	8-M22× 160× 60	8-M22× 60× 50	12-M22× 160× 40	8-M22× 60× 50
400	16	12-M22× 175× 45	8-M22× 60× 50	12-M24× 190× 45	8-M24× 70× 50
450	18	12-M22× 185× 45	8-M22× 60× 50	16-M24× 205× 45	8-M24× 70× 50
500	20	16-M22× 205× 45	8-M22× 60× 50	16-M24× 215× 45	8-M24× 70× 50
600	24	16-M24× 230× 50	8-M24× 70× 54	20-M30× 255× 50	8-M30× 70× 60

■ 自锁螺栓

		JIS5K		JIS10K		ANSI125Lb/150Lb	
mm	inch	自锁螺栓	长螺栓	自锁螺栓	长螺栓	自锁螺栓	长螺栓
50	2		8-M12× 30× 28		8-M16× 35× 33		8-U5/8-11UNC× 35× 30
65	2 1/2		8-M12× 35× 33		8-M16× 35× 33		8-U5/8-11UNC× 40× 30 (8-U5/8-11UNC× 35× 30)
80	3		8-M16× 35× 33	4-M16× 125× 30	8-M16× 35× 33		8-U5/8-11UNC× 45× 38 (8-U5/8-11UNC× 40× 30)
100	4	4-M16× 130× 30	8-M16× 40× 38	4-M16× 130× 30	8-M16× 40× 38	4-U5/8-11UNC× 165× 50	8-U5/8-11UNC× 45× 38
125	5	4-M16× 130× 30	8-M16× 40× 38	4-M20× 150× 40	8-M20× 45× 41	4-U3/4-10UNC× 175× 55	8-U3/4-10UNC× 50× 44
150	6	4-M16× 140× 35	8-M16× 40× 38	4-M20× 155× 40	8-M20× 45× 41	4-U3/4-10UNC× 175× 55	8-U3/4-10UNC× 50× 44
200	8	4-M20× 155× 40	8-M20× 45× 41	8-M20× 155× 40	8-M20× 50× 46	4-U3/4-10UNC× 175× 55	8-U3/4-10UNC× 55× 44
250	10	8-M20× 165× 40	8-M20× 50× 46	8-M22× 175× 45	8-M22× 55× 50	8-U7/8-9UNC× 215× 55	8-U7/8-9UNC× 60× 50
300	12	8-M20× 175× 40	8-M20× 55× 51	12-M22× 185× 45	8-M22× 60× 55	8-U7/8-9UNC× 215× 55	8-U7/8-9UNC× 60× 50
350	14	8-M22× 185× 45	8-M22× 60× 50	12-M22× 185× 45	8-M22× 60× 50	8-U1-8UNC× 225	8-U1-8UNC× 70× 57
400	16	12-M22× 205× 45	8-M22× 60× 50	12-M24× 220× 50	8-M24× 70× 50	12-U1-8UNC× 255	8-U1-8UNC× 75× 57
450	18	12-M22× 225× 45	8-M22× 60× 50	16-M24× 230× 50	8-M24× 70× 50	12-U1 1/8-8UN× 280	8-U1 1/8-8UN× 85× 63
500	20	16-M22× 230× 45	8-M22× 60× 50	16-M24× 245× 50	8-M24× 70× 50	16-U1 1/8-8UN× 295	8-U1 1/8-8UN× 85× 63
600	24	16-M24× 275× 50	8-M24× 70× 54	20-M30× 290× 60	8-M30× 70× 60	16-U1 1/4-8UN× 340	8-U1 1/4-8UN× 95× 70

【示例】

自锁螺栓:

12 - M22 185 45
 本数 口径 (M) 螺栓长度 (L) 有效长度 (S)

六角螺栓: 4 - M30 95 65
 本数 口径 (M) 螺栓长度 (L) 有效长度 (S)

自锁螺栓:

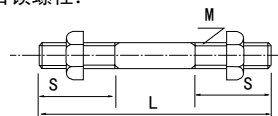

六角螺栓:

